

1 Traçage & perçage des trous de fixation Trace & drill the mounting holes

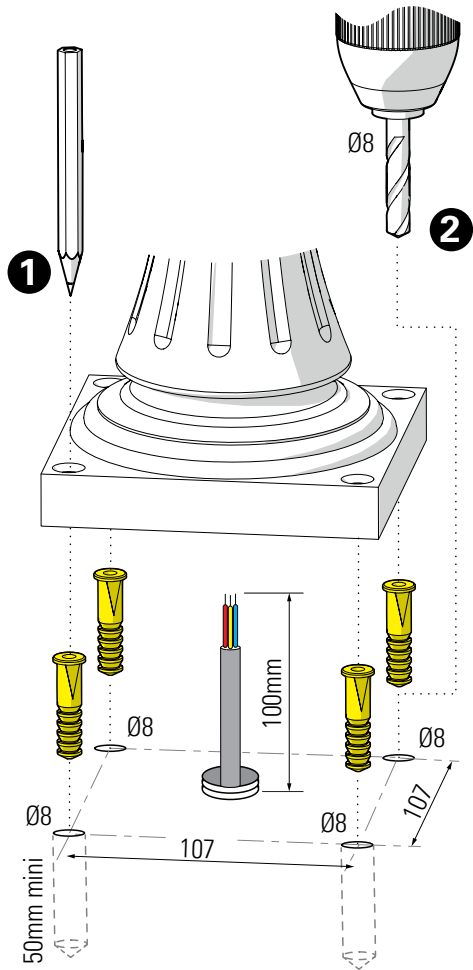

2 Raccordement électrique Connect electrical wires

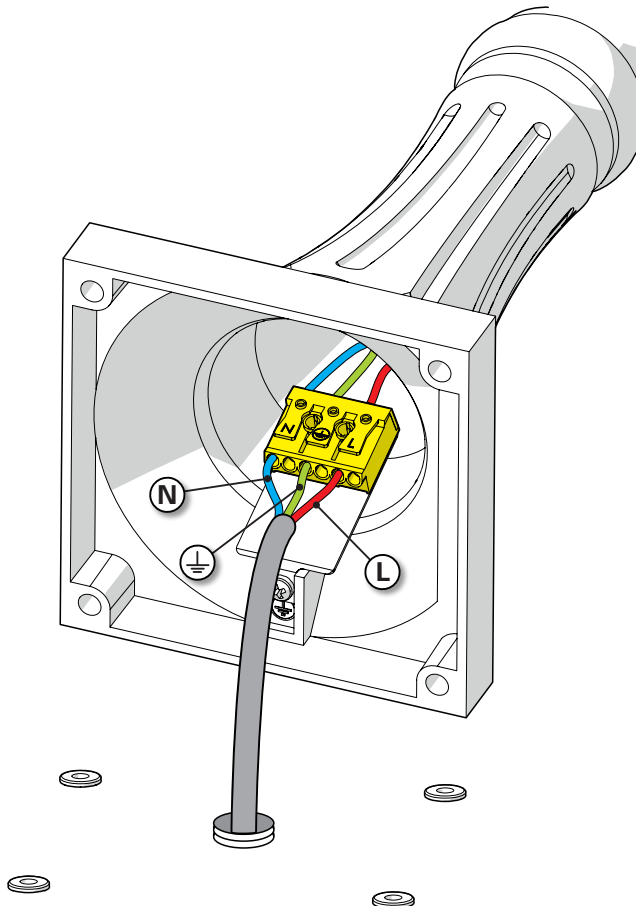

3 Fixation du luminaire Fix the luminaire

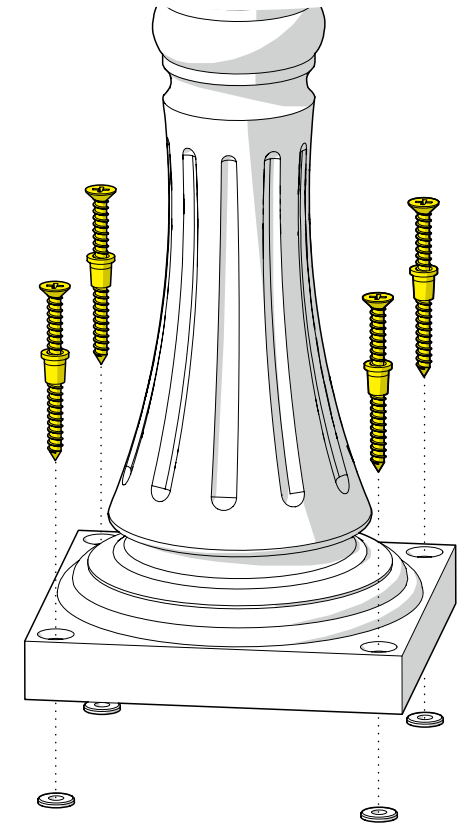

4 Installation des verres
Put in place glasses

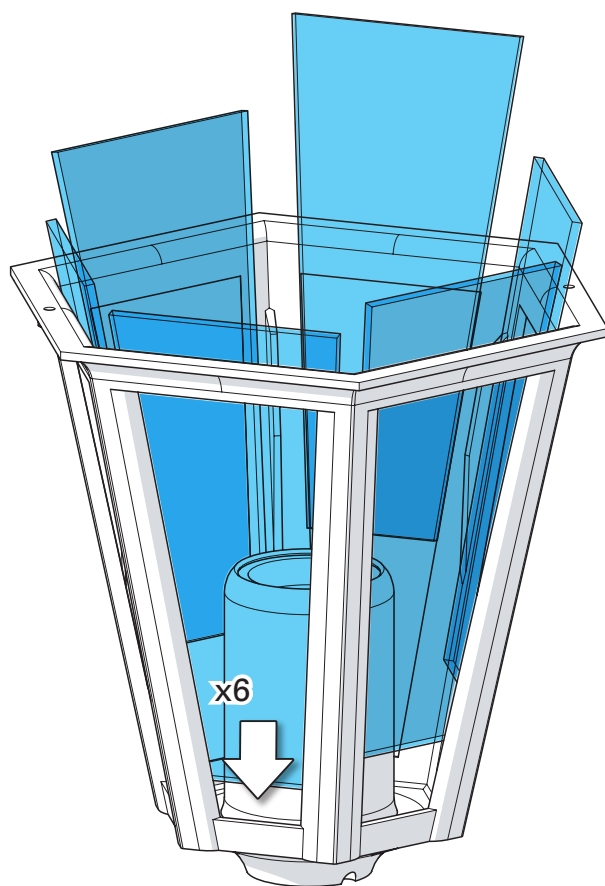

5 Montage de la lampe & du chapiteau
Put in place light-bulb & assemble the dome

