

1 Fixation de la base au sol
 Fix the mast base to the ground

2 Montage du bras
 Assemble the bracket

3 Raccordement électrique
 Connect electrical wires

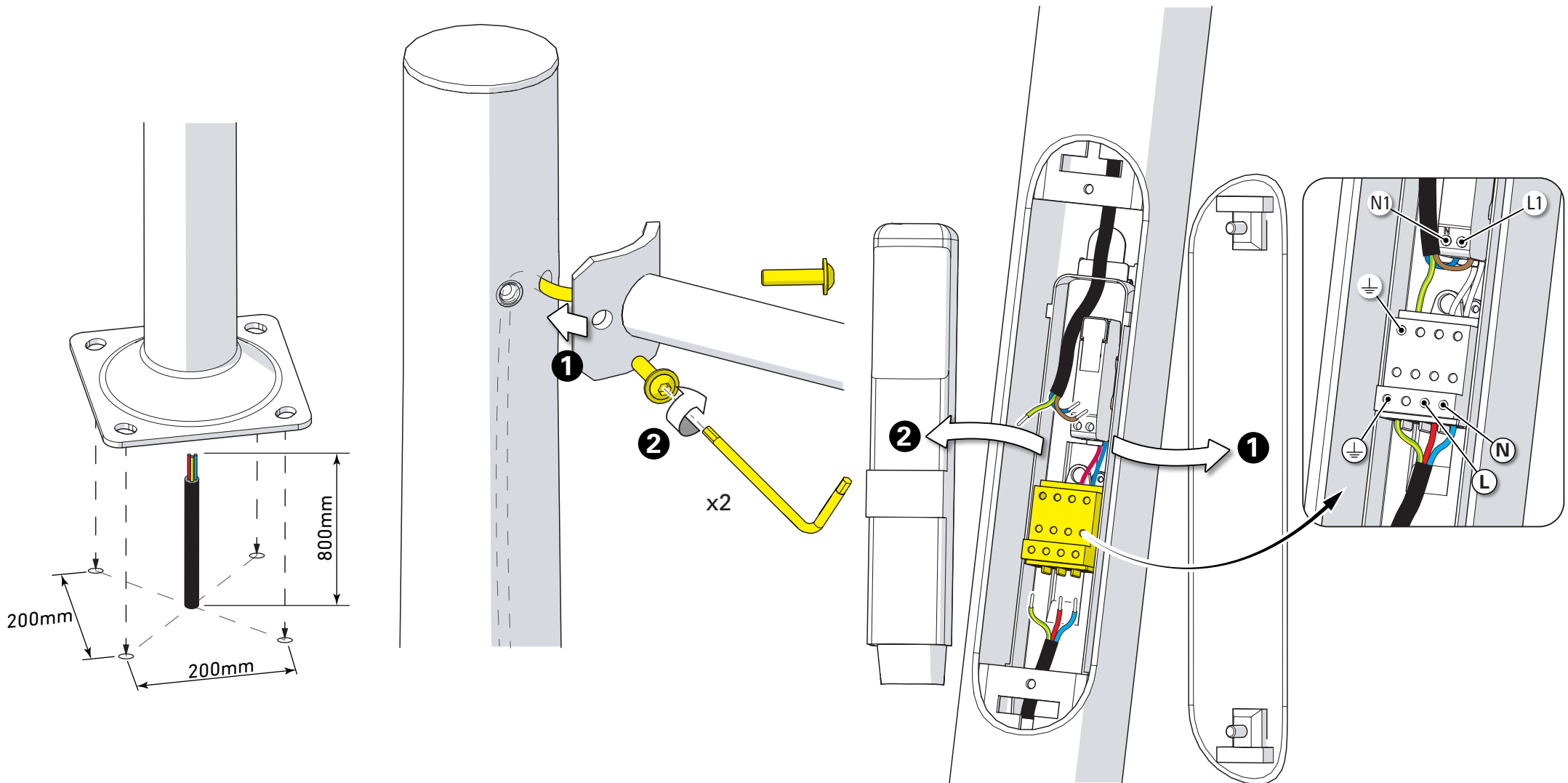

4 Fermeture de la trappe
Close the access door

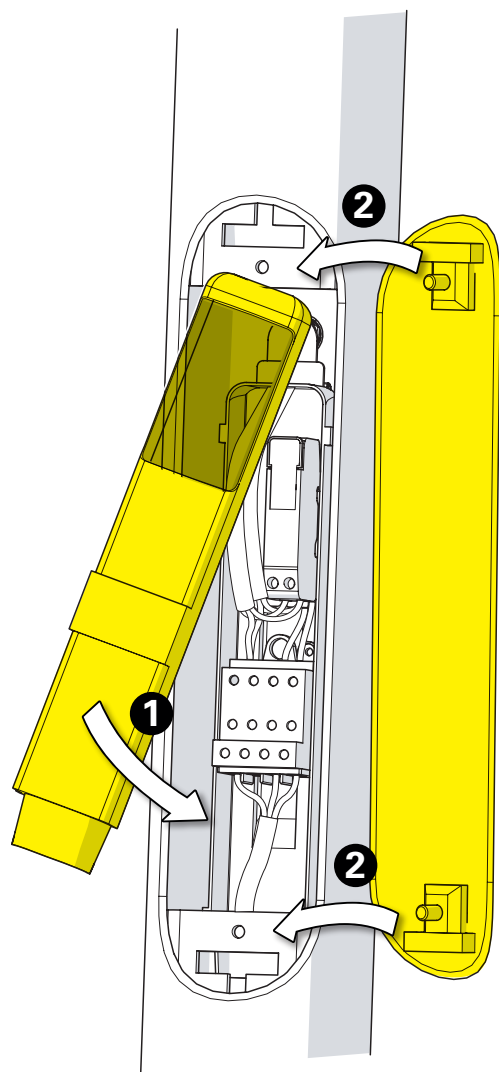

5 Montage de la lampe
Install the light-bulb

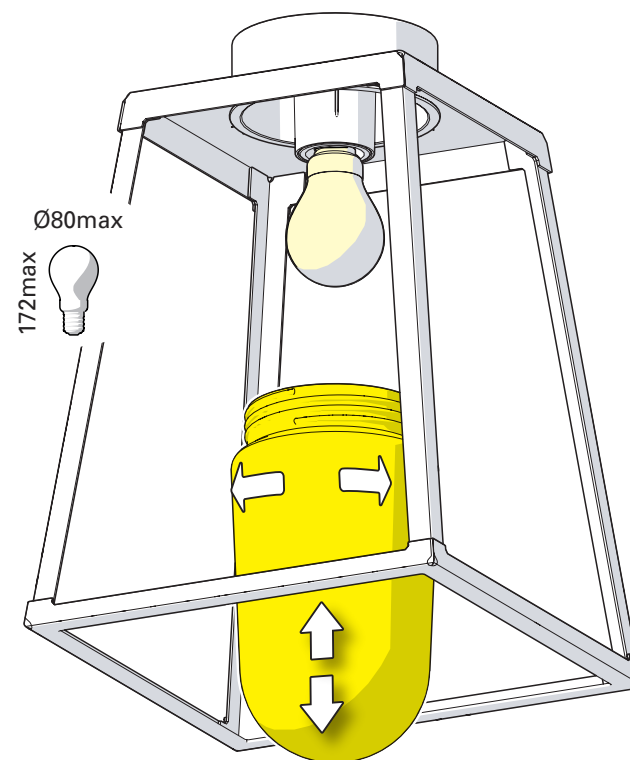

IP65



visser délicatement le verre
pour une bonne adaptation du joint
screw the glass diffuser softly to
ensure gasket correct positioning