

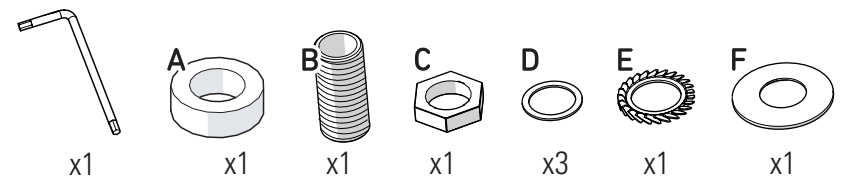

Class 1
E27

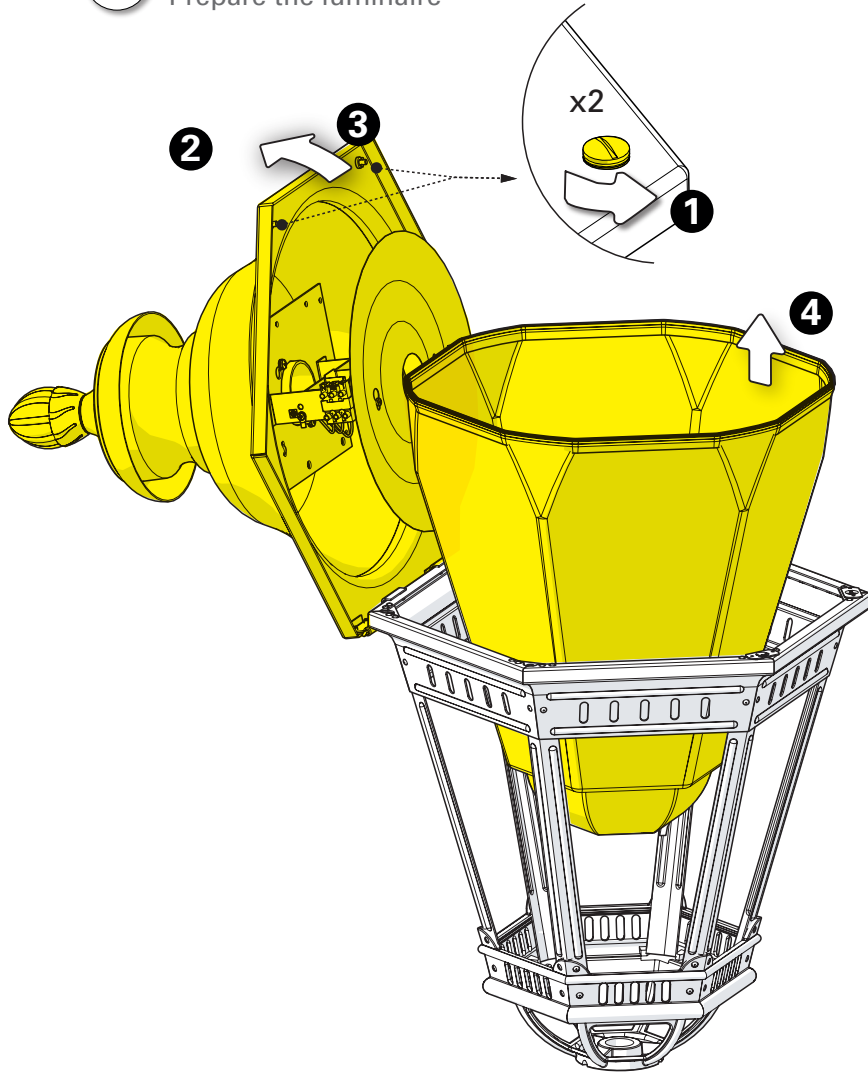

1 Préparation de la lanterne Prepare the luminaire



2 Montage du luminaire sur le bras Mount the head on the bracket

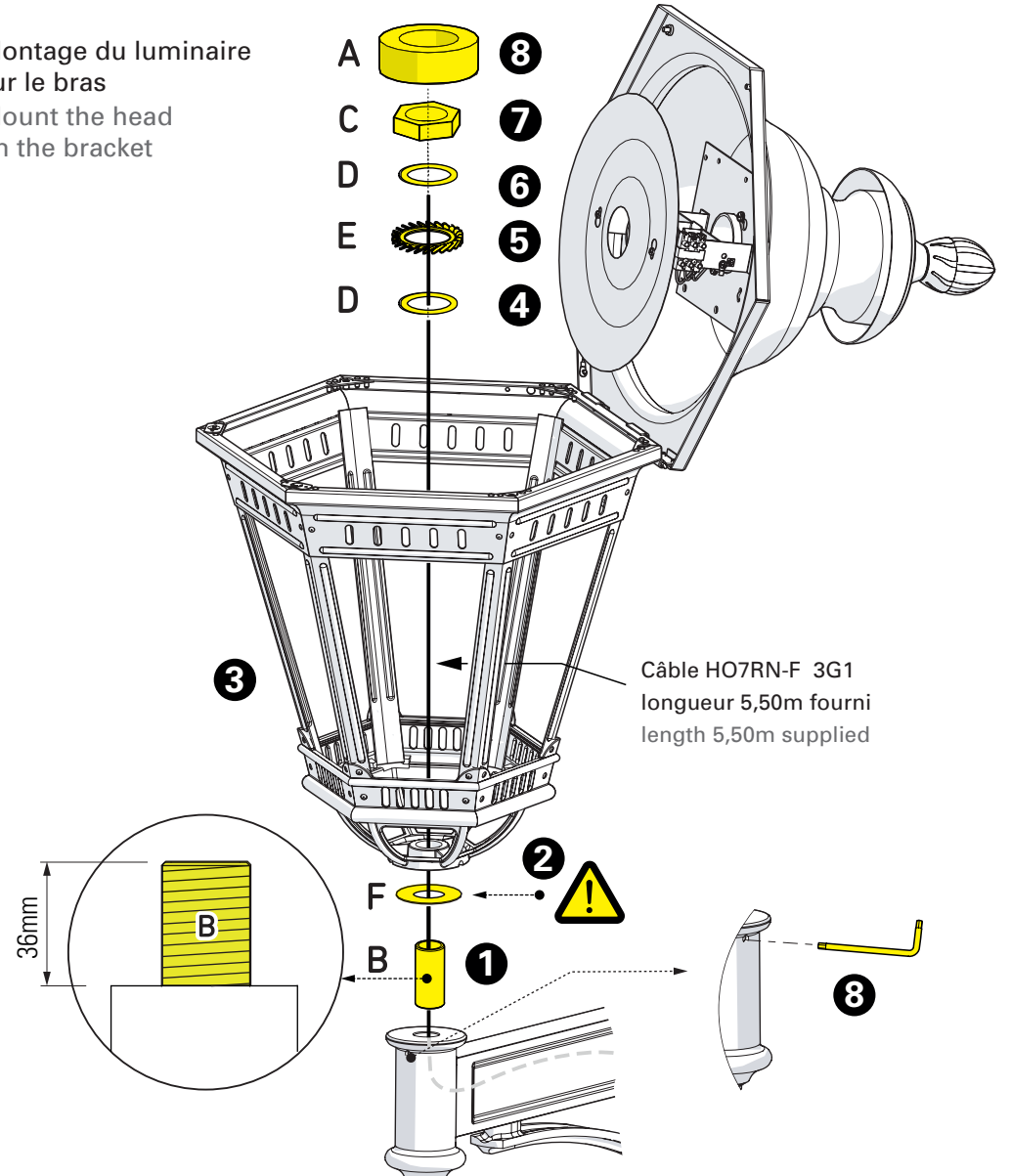

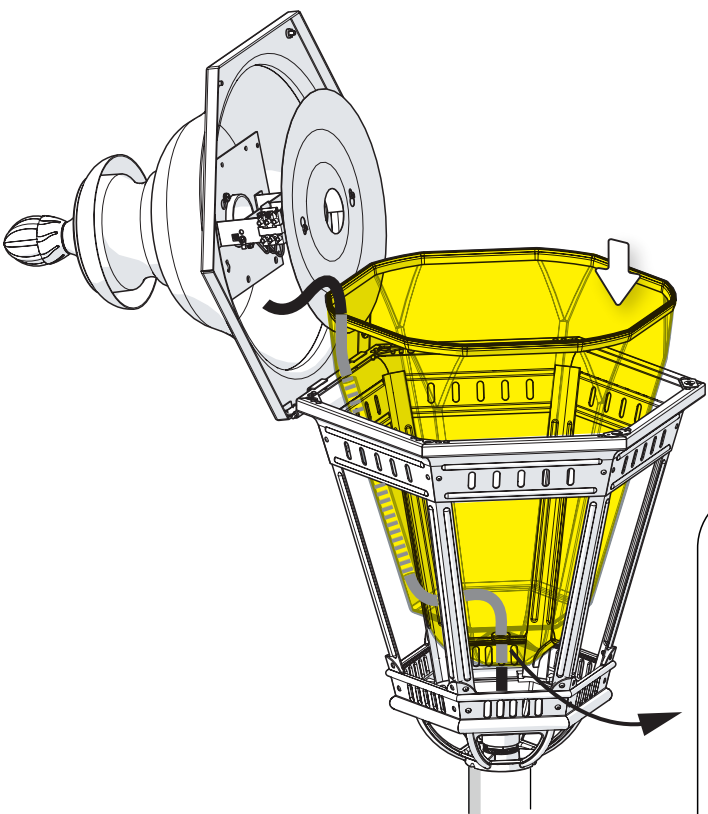

3 Montage de la verrine & passage du câble
Put in place the glass and insert cable into the conduit

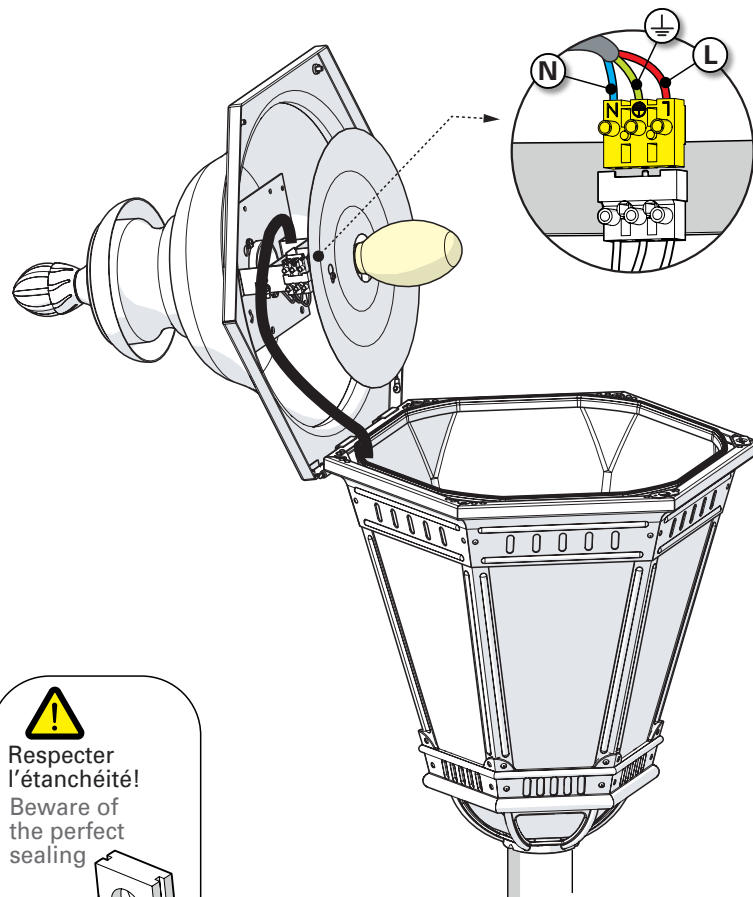

4 Raccordement électrique & montage de la lampe
Connect electrical wires & lamp mounting



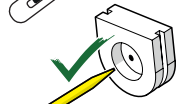

Respecter l'étanchéité!
Beware of the perfect sealing

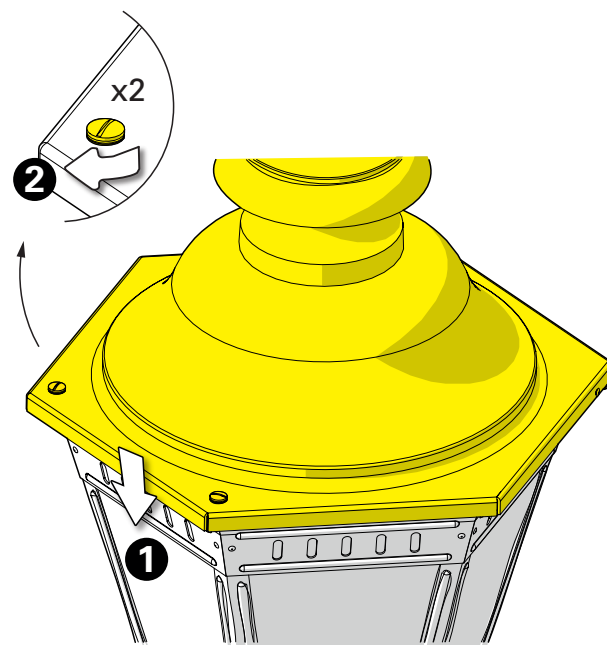

percer à la pointe
pierce with nail

5 Fermeture du chapiteau
Close the dome

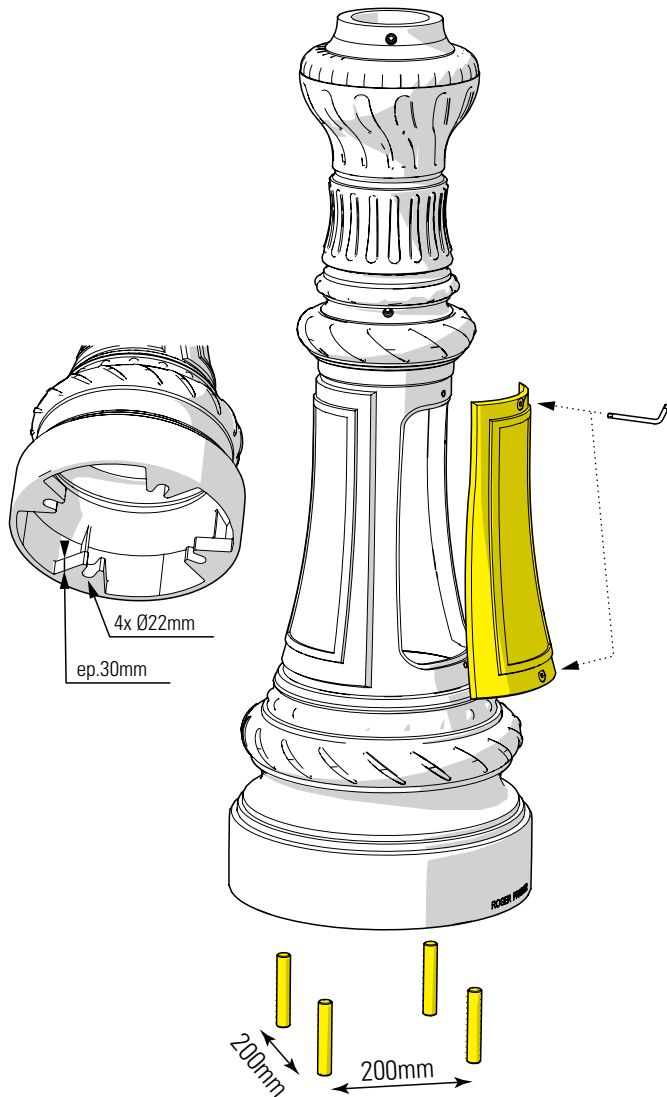

6 Fixation de la base au sol
Fix the mast base to the ground



7 Montage du mât
Fit the mast into the base

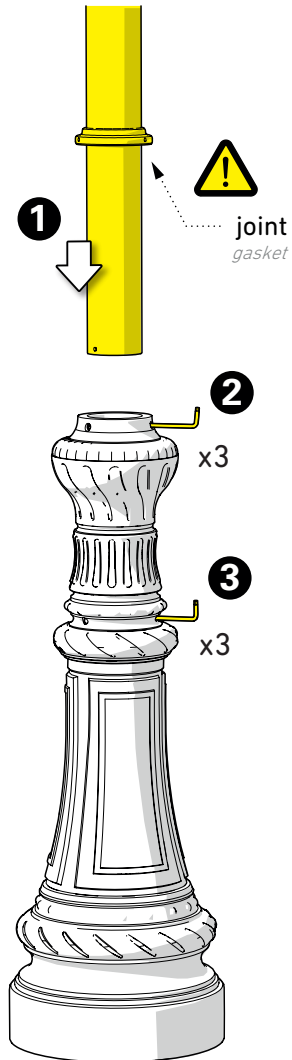

8 Montage des bras
Mount the brackets on the mast

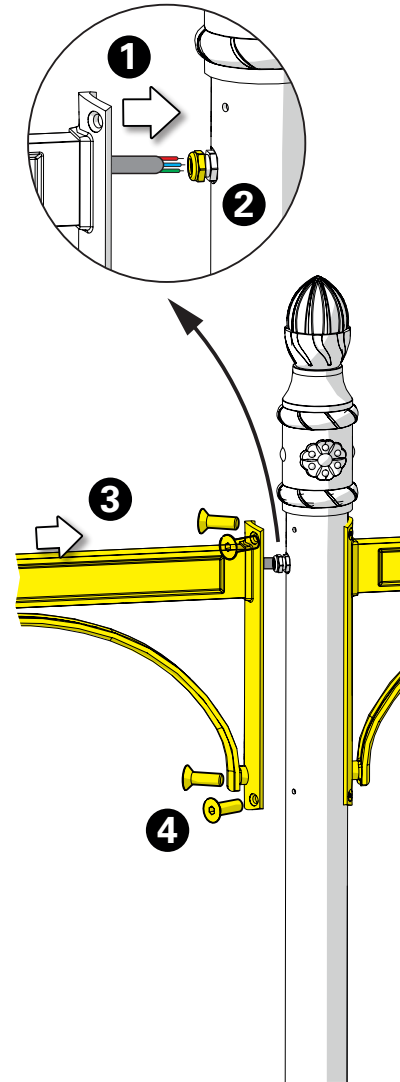

9 Raccordement électrique
Connect electrical wires

